

# 伸展桌 FESTA XL 安裝說明書

左滑軌

FESTAL XL—適用櫃寬900mm；板厚18mm；桌面長度1378mm；  
滑軌最大展開長度1816mm

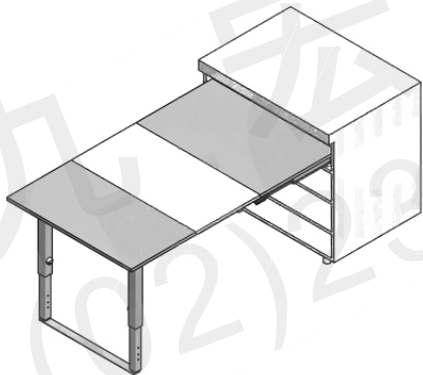

INCLUDED IN THE PACKAGING 包裝明細

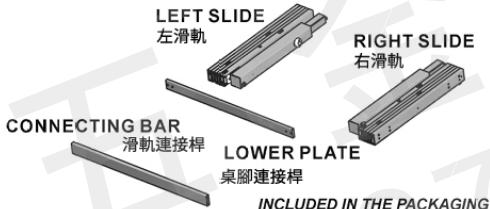

ACCESSORIES BAG INCLUDING 螺絲配件包

-  n. 5 Allen key / 5號六角板手
-  n. 4 Allen key / 4號六角板手
-  n. 3 Allen key / 3號六角板手
-  B - Socked head cap screw M6x12 (x 12) / M6x12內六角螺絲
-  C - Socked head cap screw M6x60 (x 4) / M6x60內六角螺絲
-  D - 12x8 mm M6 Brass bush (x 12) /  $\Phi$ 8x12銅塞
-  E - Striker for plane hook (x 2) / 桌板固定片
-  F - Tapered wood screw 3,5x16 (x 4) /  $\Phi$ 3.5x16木牙螺絲
-  G - Socked head tapered cap screw M6x16 (x4) / M6x16內六角螺絲

# GENERAL DIMENSIONS 規格尺寸圖

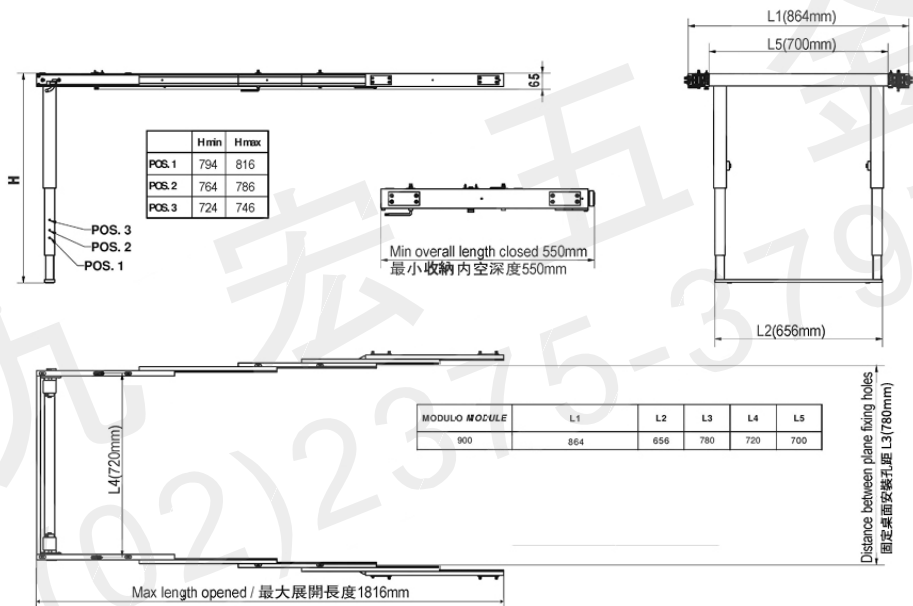

# CABINET REQUIRED INTERNAL DIMENSIONS

## 櫃體內空安裝尺寸

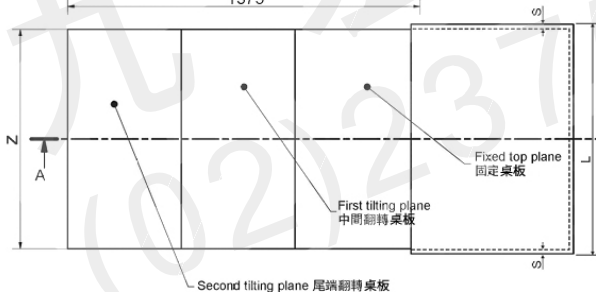
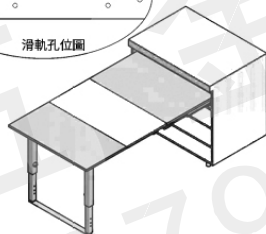
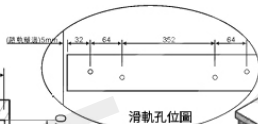
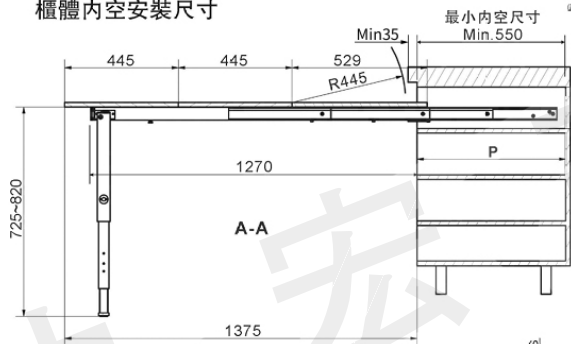

DIMENSIONE - DIMENSION	SYMBOL	
VERTICAL FREE SPACE 安裝空間高度	H	MIN: 170
PLANES THICKNESS 櫃體側板厚度	S	18
INTERNAL FREE SPACE 安裝空間深度	P	MIN: 550
PLANES WIDTH 桌板寬度	Z	L - S x 2 - 6
CABINET WIDTH 櫃體寬度	L	900

## HOLES FOR MECHANISM POSITION

### 櫃體側板孔位圖

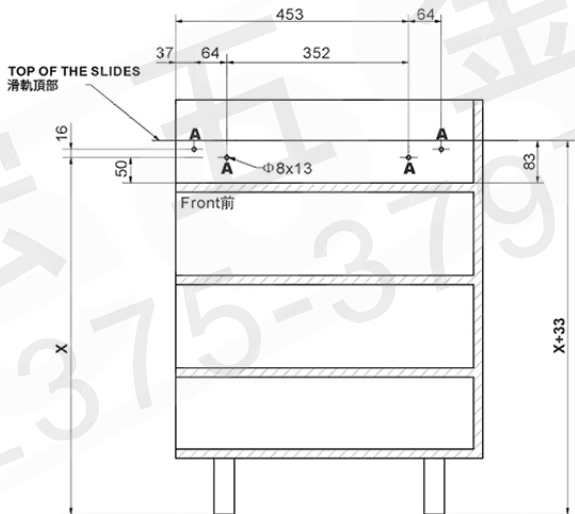
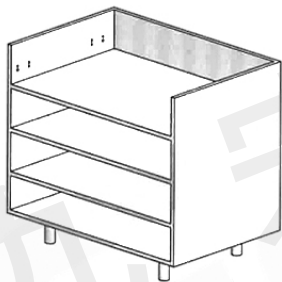

THE INDICATED 50 mm DIMENSION IS TO ALLOW  
A FREE SPACE BETWEEN THE BOTTOM OF THE SLIDES  
AND THE PLANE OF 20 mm

滑軌下排安裝孔至少離底部層板50mm以上  
以保證滑軌離底部層板20mm以上空間

# TABLE TOP PLANES DRILLING

## 桌板安裝孔位圖

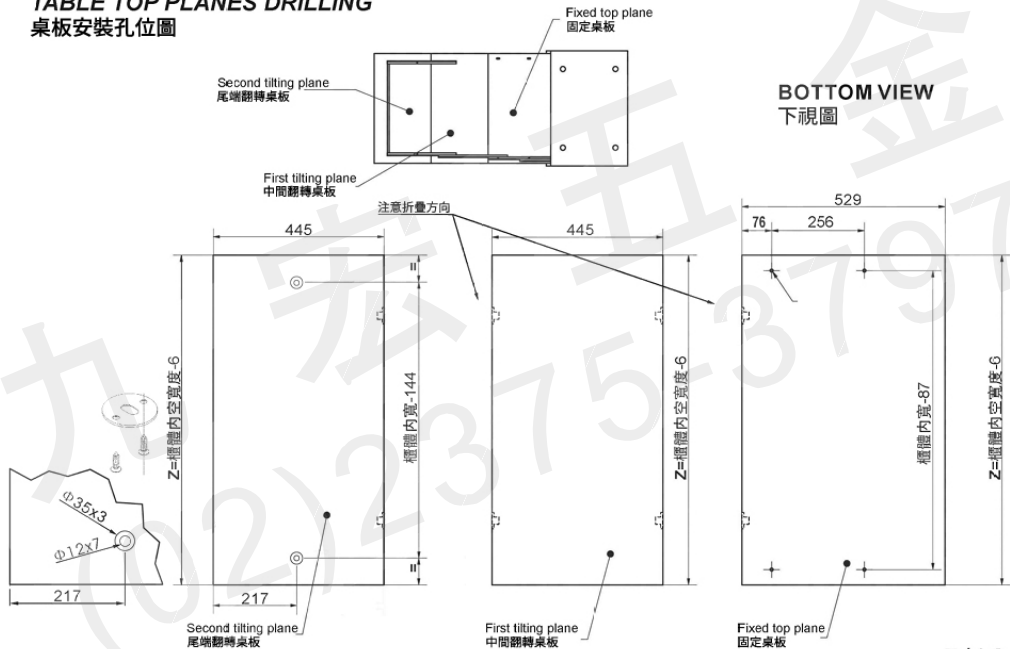

**BOTTOM VIEW**  
下視圖

## CABINET PREPARATION 滑軌組裝於櫃體預備步驟

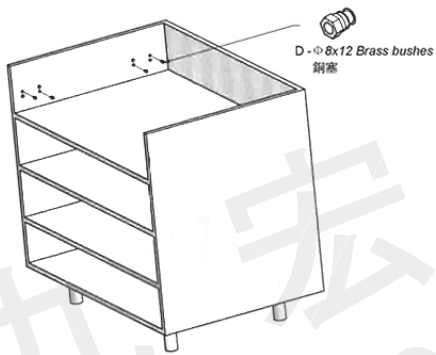

2. Disassembly the external slides unscrewing the indicated screw  
依下方圖示分離滑軌外軌定位螺絲

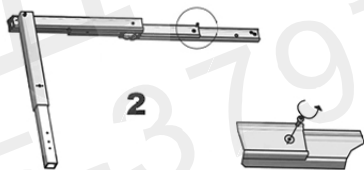

L - M5x10 ISO 7380 screw / M5x10內六角螺絲



N.4 Socked wrench / 4號六角板手

## MOUNTING OF THE MECHANISM ON THE CABINET 滑軌組裝於櫃體

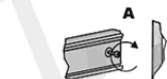
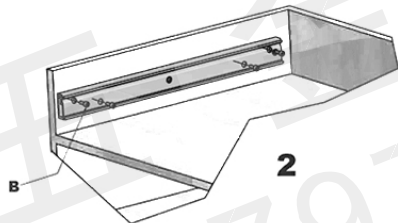
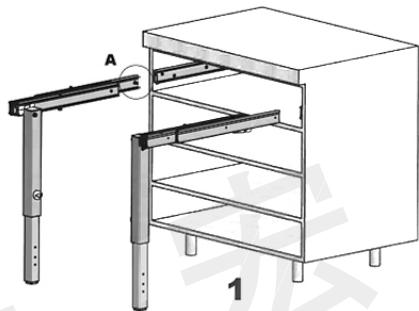

H- Socket head cap screw M5x6  
M5x6內六角螺絲



B- Socket head cap screw M6x12  
M6x12內六角螺絲



N.4 Socket wrench  
4號六角板手



N.5 Socket wrench  
5號六角板手

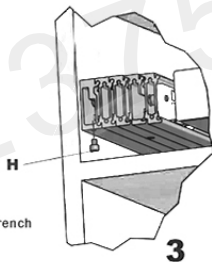

1- Unscrew till the external slide is free,  
Extract the external slide from the mechanism  
鬆開A圖示螺絲，分離外軌

2 - Mount the external slides on the cabinet sides  
using 4 "B" screws M6x12 on each side.  
Tighten the screws using the n. 5 Allenkey.  
Insert the mechanism on the external slides  
and screw the two screws dismantled before.  
用5號六角板手把M6x12內六角螺絲固定滑軌於側板  
再把之前分離的軌道組裝還原

3 - After closing the mechanism, screw under the  
front of the external slides the two "H" M5x6  
screw using the n. 4 Allen key.  
用4號六角板手把M5x6內六角螺絲依圖示固定於滑軌上

## PLATES ASSEMBLY 滑軌連接桿及桌腳連接桿組裝

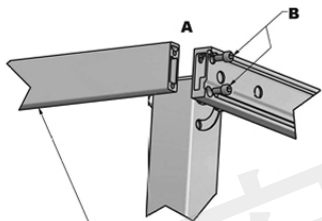

CONNECTING BAR  
連接桿

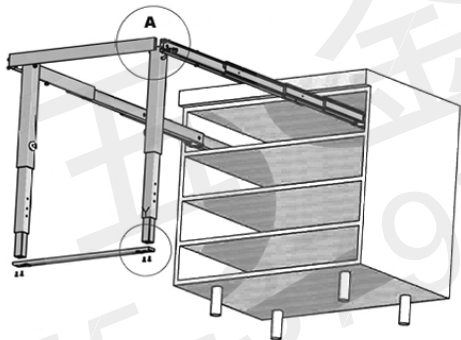

n°4 Socked wrench  
4號六角板手



n°5 Socked wrench  
5號六角板手



B- Socked head cap screw M6x12  
M6x12內六角螺絲



G- Socked head tapered cap screw M6x16  
M6x16內六角螺絲

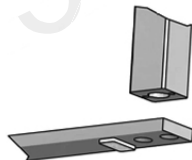

LOWER PLATE  
桌腳連接桿





# PLANES ASSEMBLY 桌板與滑軌組裝

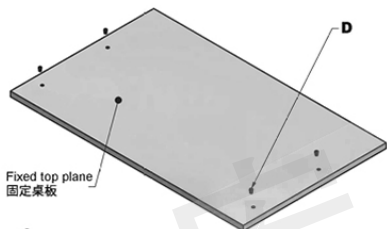

D - 12x8 M6 Brass bush  
Φ8x12銅塞

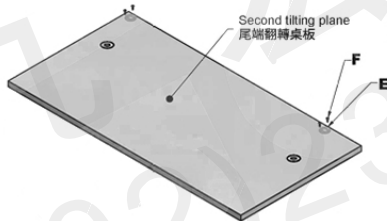

E - Striker for plane hook  
桌板固定片



F - Tapered wood screw 3,5x16  
Φ3.5x16木牙螺絲

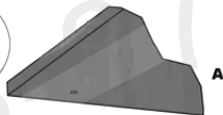
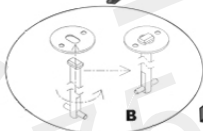
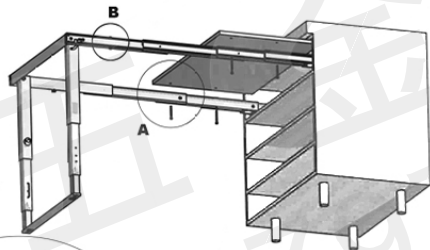

C - Socketed head cap screw M6x60  
M6x60內六角螺絲



n°5 Allen key  
5號六角板手

## LEGS ASSEMBLY AND HEIGHT REGULATION 桌腳組裝及高度調節



n°4 Socked wrench  
4號六角板手



n°3 Allen key  
3號六角板手

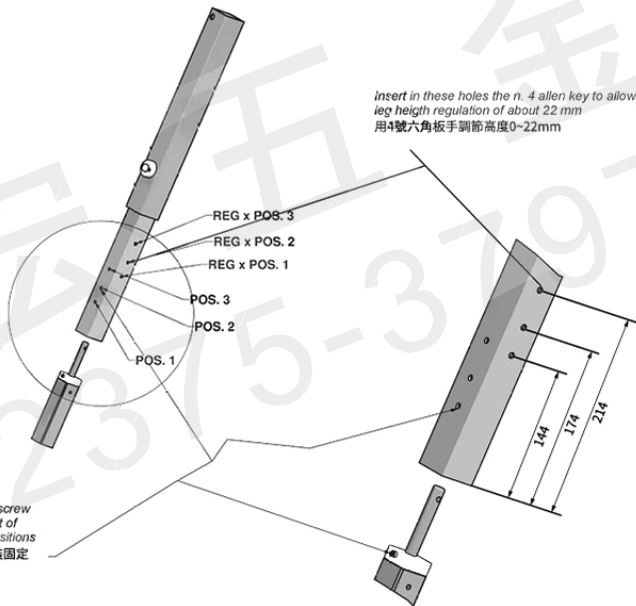

## FUNCTIONING SEQUENCE 操作示意

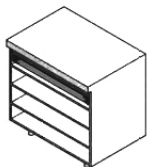

CLOSED  
關閉狀態

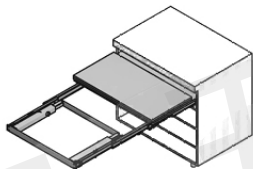

SLIDES OPENING  
拉出滑軌

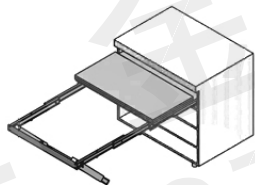

LEG RELEASE AND ROTATION  
伸展並旋轉桌腳

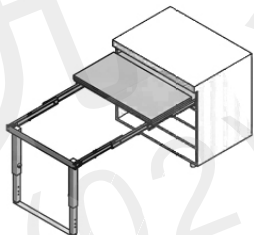

LEG EXTENSION AND LOCK  
鎖緊桌腳

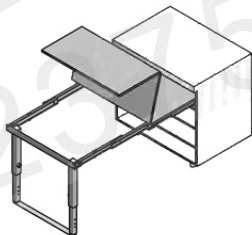

PLANES OPENING  
桌板展開

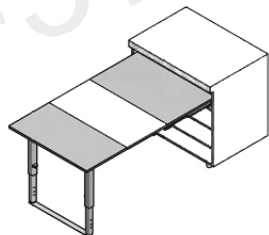

OPENED  
完全打開

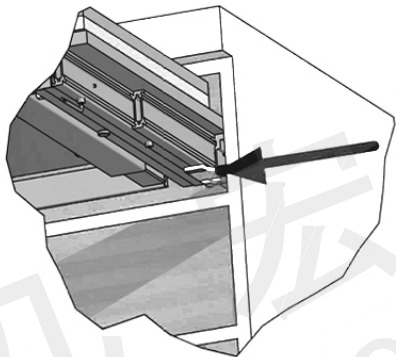

TO CLOSE THE MECHANISM PUSH  
TOWARD THE INSIDE THE TWO  
RED PLASTIC PARTS  
收納滑軌前需解鎖  
將圖示部分向內側推開

TO ROTATE THE LEG, TURN THE TWO  
BLACK LEVERS SITUATED ON THE  
INTERNAL SLIDE  
桌腳收縮及旋轉水平狀態  
確實鎖上桌腳鎖扣

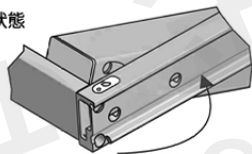

TO RETRACT THE LOWER PART OF  
THE LEG, PUSH THE GREY BUTTON  
收回桌腳前需按壓圖示按鈕

